



---

**INDICATOR FOR BALANCING ROTORS  
OF ROTATING MACHINES  
IBR-02**

**Operation manual  
IBR-02.00.000.OM**

## 1 Purpose

1.1 The indicator is designed to control vibration of rotating machines, dynamic balancing (in one and two planes) of their rotors, alignment of the shafts of horizontal machines and provides:

- 1) check of machine vibration;
- 2) determination of the rotor speed and vibration velocities at the rotor speed and their phase angles;
- 3) automatic calculation of correction masses and correction angles;
- 4) automatic calculation of displacements providing elimination of shafts misalignment.

1.2 The main users of the indicators are enterprises operating or repairing rotating machines with a rigid rotor with a speed of 300 to 15000 rpm.

## 2 Technical data

- 1) parameters to be controlled:
  - during check of machine vibration Vibration velocity (root mean square value);
  - during balancing rotors Vibration velocity (root mean square value), phase angle of vibration velocity, rotation speed;
- 2) dynamic range, dB 54;
- 3) frequency range, Hz 5-1000;
- 4) indication Liquid-crystal graphic one;
- 5) method of determination of vibration velocity phase angle Visual with a help of built-in stroboscope beam synchronized by vibration signal;
- 6) power Self-contained from external power unit;
- 7) power voltage, V  $4^{+0,2}_{-1,0}$ ;
- 8) power consumption, W 1.2;
- 9) overall dimensions, mm 205 x 80 x 50;
- 10) weight\*, kg, within 0.4;
- 11) operating position Arbitrary;
- 12) parameters of external power unit:
  - rated DC output voltage, V 4;

- rated output current, A	1;
- rated AC output voltage, V	220.

---

\*The weight of the indicator with the storage battery is indicated, the weight of the delivery set is  $0.84 \pm 0.04$  kg.

### 3 Delivery set

1) IBR-02, pcs	1;
2) storage battery (Li-ion, type 14500), pcs	1;
3) power unit БПИД-3, pcs	1;
4) vibration sensor, pcs	1;
5) hand probe, pcs	1;
6) fastening magnet, pcs	1;
6) operation manual, copies	1;
7) case, pcs	1.

### 4. Indicator design and operation

#### 4.1 Indicator design (Fig. 4.1, 4.2)

Structurally, the indicator is made in the form of a portable device, the plastic housing of which consists of two parts pulled together with rubber edge strips.

On the front side of the housing, there is a liquid crystal display and inscriptions explaining the purpose of the controls.

In the upper wall of the housing, there is a built-in stroboscope window. There are two buttons on the left side of the housing:

«» – to switch on/ off the indicator and «**Enter**» – to control the indicator.

## General view of IBR-02 indicator



Fig. 4.1

## Accessories for IBR-02 indicator









Fastening magnet	Hand probe	Vibration sensor	BPID-3 power unit
			

Fig. 4.2

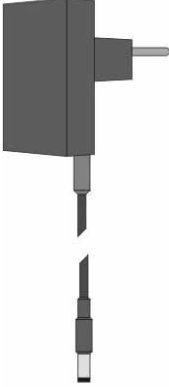
On the right wall of the housing, there are located jacks «», «**4V, 1A**» – to connect a vibration sensor and BPID-3 external power unit (hereinafter referred to as «the power unit») to the indicator, respectively, and buttons «», «» – to choose the required item of the display menu or to change the value of the particular parameter. Button «» also serves to switch the indicator to the serviceability monitoring mode. A short (less than 1 s) pressing of button «» or button «» changes the displayed value of the parameter by 1, and long pressing changes the value with increasing speed.

On the back side of the housing, there are inscriptions explaining the purpose of the indicator jacks and containing basic information about the jack, as well as an inscription indicating the location of the stroboscope window.

Inside the housing, there is a printed circuit board with components of the indicator and storage battery circuits.

### 4.2 Indicator operation

4.2.1 In case of checking the vibration of the machine, the vibration velocity (root mean square value (RMS value)) is measured in the range of 5-1000 Hz.

4.2.2 In case of balancing the rotor, the rotor rotation speed, vibration velocities (RMS value) at the rotor rotation speed and their phase angles during test runs are determined, and with their help, corrective masses and correction angles are automatically calculated.

4.2.3. In case of aligning the shafts of horizontal machines, the readings of dial indicators installed on the half-couplings or shafts are recorded at the positions «9 h», «0 h», «3 h» (when viewed on the side of the moving machine), and on their basis parallel and angular misalignment of the shafts in the vertical and horizontal planes and displacements ensuring their elimination are calculated.

### **Note**

**To align the shafts, it is necessary to have a device for checking the alignment of shafts with dial indicator (it is not included in the delivery set of the indicator).**

## **5 Safety requirements**

5.1 Read this manual before working with the indicator.

5.2 When checking vibration and balancing the rotor, the machine must be reliably grounded.



## **6 Preparation for operation**

6.1 Carry out an external visual inspection of the indicator.



6.1.1 Check the completeness according to the delivery set.

6.1.2 Check for unavailability of external damage to the housing and cable of the vibration sensor.

6.2 Check indicator power supply.

Switch on by pressing button «». In this case, the display shall show icon «», and in 3 s – the menu.

If on switching on the indicator, the recommendation «**Charge the battery**» appears on the display, then it is necessary to charge the storage battery. For this purpose:

- 1) switch on the indicator by pressing button «»;
- 2) connect the power unit to the indicator (see Figs. 4.1, 4.2);
- 3) connect the power unit into the AC network with voltage of 220 V and frequency of 50 Hz. In this case, LEDs «» and «**Charge**» on the power unit housing shall light up;
- 4) disconnect the power unit from the indicator and from network.



## Notes

1. The storage battery shall be charged only with the delivered power unit.
2. The storage battery is also charged when the indicator is energized from the power unit.
3. When checking the vibration of the machine for up to 1 mm/s, it is recommended to use only the internal power source (storage battery), because the interference possible in this case, when the external power source is used, can distort the useful signal.
4. Turn off the indicator by pressing the button «».



## 7 Operation

### 7.1 Check of machine vibration.

7.1.1 Connect the hand probe or a holding magnet to the vibration sensor and connect it to the indicator (see Figs. 4.1, 4.2).

7.1.2 Switch on the indicator, choice item «**Check of vibration**» with the help of buttons «», «», and press button «**Enter**».

## Notes

1. Icon «» points out to the chosen item.
2. When the indicator is switched on, icon «» is located opposite the menu item, which was activated before its switching-on.

7.1.3 Install the vibration sensor on the end shield of the running machine in the appropriate direction (radial vertical, radial horizontal or axial). In this case, the display alternately displays the value of vibration velocity (in mm/s) and the vibration assessment zones corresponding to them for three classes

of machines (for example, reading «1C; 2B; 3B» corresponds to reading «2.4», where the figures indicate the classes of machines, and the letters – the vibration assessment zones).

7.1.4 Remove the vibration sensor from the machine.

7.1.5 Assess the machine vibration in the examined direction, using the indicator readings and table 7.1.

**Notes**

1. The machine vibration assessment zones – green one (normal), yellow one (satisfactory), red one (unsatisfactory) - are accepted on the basis of the international standard ISO 10816-1.

2. The threshold values of vibration velocity are shown in Table 7.1.

Table 7.1 Machine vibration assessment zones

Vibration velocity, mm/s	Machine vibration assessment zones		
	Class 1 (<15 kW)	Class 2 (15-75 kW)	Class 3 (>75 kW)
71 - 112	D	D (unsatisfactory)	D
45 - 71			
28 - 45			
18 - 28			
11.2 - 18			
7.1 - 11.2			
4.5 - 7.1	C	C (satisfactory)	C
2.8 - 4.5			
1.8 - 2.8			
1.12 - 1.8	B	B (satisfactory)	B
0.71 - 1.12			
0.45 - 0.71	A	A (normal)	A
0.28 - 0.45			

7.1.6 Switch off the indicator.



## 7.2 Check of rotor imbalance.

7.2.1 Disconnect the machine from the plant, if it works as a part of the plant, or install it on shock absorbers if it is not at the place of its normal installation.

7.2.2 Install on the end of the shaft a dial scale with a diameter of 50 - 100 mm with an angle marking, having a step of not more than 10 degrees directed against the direction of rotation of the rotor (Figs. 7.1, 7.2). Mark with a bold radial line or point the angle mark (zero mark).

### Note

The scale dial can be cut with scissors from the paper copy of Fig. 7.1 or Fig 7.2.

7.2.3 Mark on the end shields (with a marker, chalk, etc.) the places of installation of the vibration sensor in the radial vertical and radial horizontal directions.

7.2.4. Start the machine (zero startup) and switch on the indicator.

7.2.5 Choose item «**Check of imbalance**» and press button «**Enter**».

7.2.6 Carry out synchronization of the stroboscope. For this purpose, by pressing buttons «▲», «▼», set the known value of the rotor rotation speed on the display, then, aiming the stroboscope at the scale dial, correct this value, trying to stop the image of the scale dial with one zero mark, and press «**Enter**».

If the value of the rotor rotation speed is unknown, then it is necessary to determine it. To do this, you first need to set the value on the display to  $n = 15000$  rpm, aim the stroboscope at the dial and hold down button «▼» until the image of the scale dial with one zero mark appears. Then with the help of buttons «▲», «▼», it is necessary to provide a stop of this image and press «**Enter**».

### Notes

1. The image of the limb can be considered stopped if it moves slowly with an angular velocity of not more than 0.1 rev/s.

2. Icon «▶» in flashing mode indicates the parameter to be entered into the indicator memory.

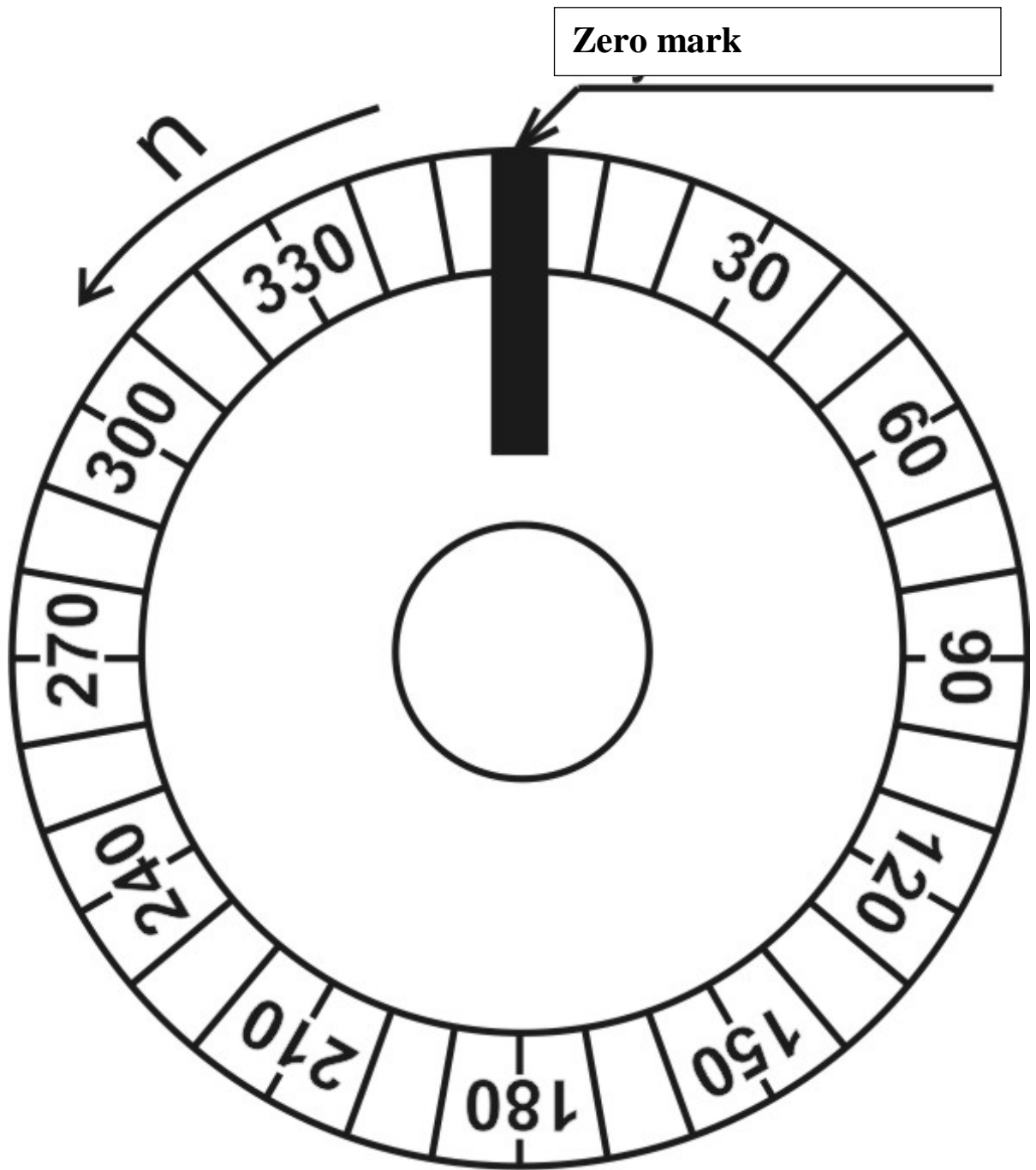

Fig. 7.1. Example of marking the scale dial used in case of dynamic balancing, when the rotor is rotated counterclockwise.

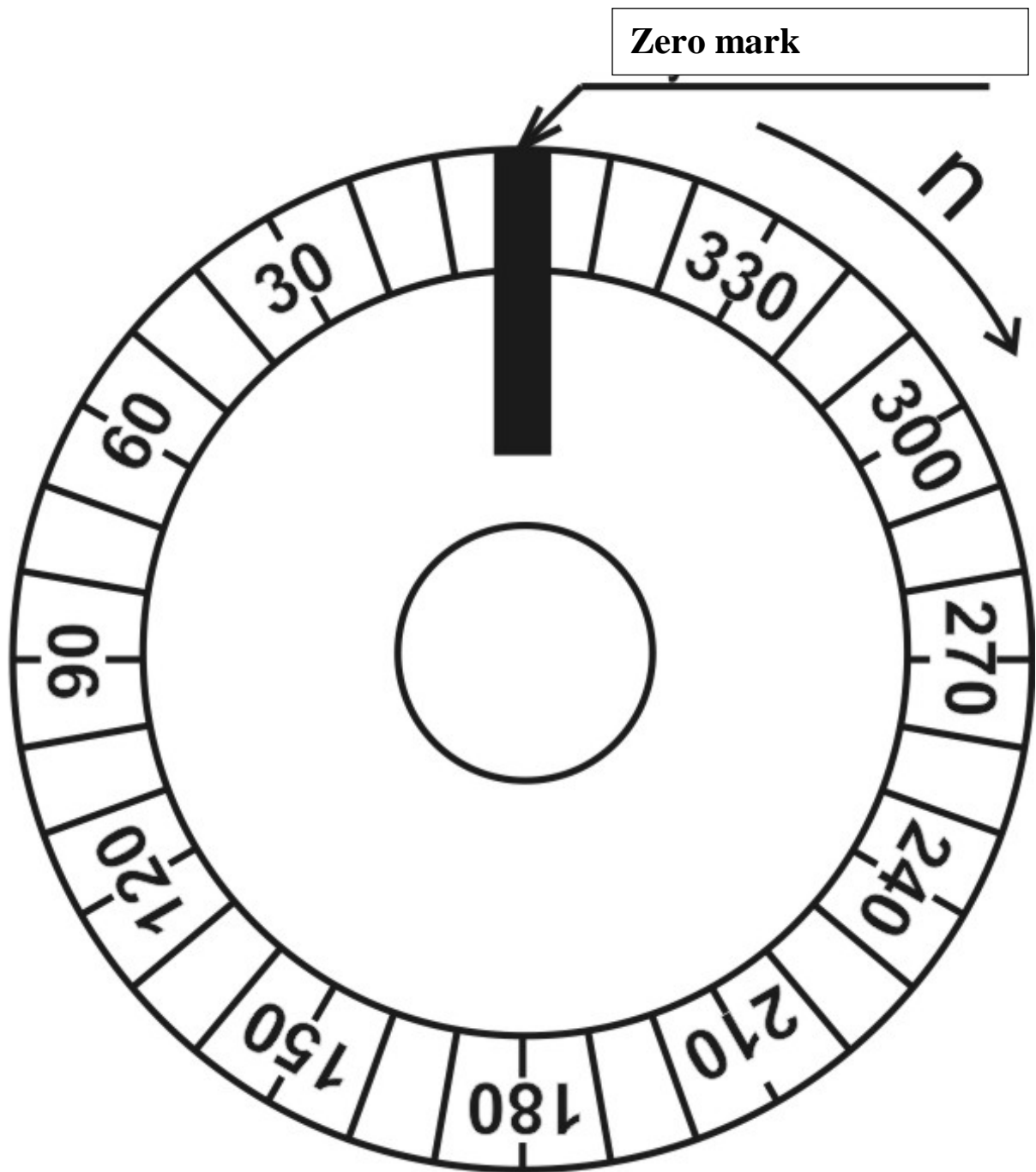

Fig. 7.2. Example of marking the scale dial used in case of dynamic balancing, when the rotor is rotated clockwise.

7.2.7 Having installed the sensor in the points marked on the supports, measure the values of vibration velocities. Using the largest of the measured values, select the direction (vertical or horizontal), in which the measurements will be carried out during balancing (if it is necessary), and number the supports (in case of one-plane balancing, the support is assigned number 1).

### **Note**

The single-plane rotor balancing is recommended in cases where it is known that its imbalance is due to the presence of an unbalanced element at the end of the shaft (coupling, pulley, fan, etc.).

7.2.8 Choose the type of balancing (one-plane or two-plane one) and press «**Enter**».

### 7.3 One-plane balancing of the rotor

7.3.1 Install the sensor on support 1 and press «**Enter**».

7.3.2 Measure the value of the vibration velocity of support 1 and press «**Enter**».

7.3.3 In 10-15 seconds after the appearance of message «**Wait for the stroboscope to turn on**», the message «**Watch the angle**» will appear, and the stroboscope will turn on.

Aim the stroboscope at the scale dial, determine the value of the phase angle of the vibration velocity of support 1 (it shall be taken into account that the place on the scale dial marking corresponding to the angle to be determined is in the same axial plane with the sensor on the sensor side), and press «**Enter**» (Fig. 7.3).

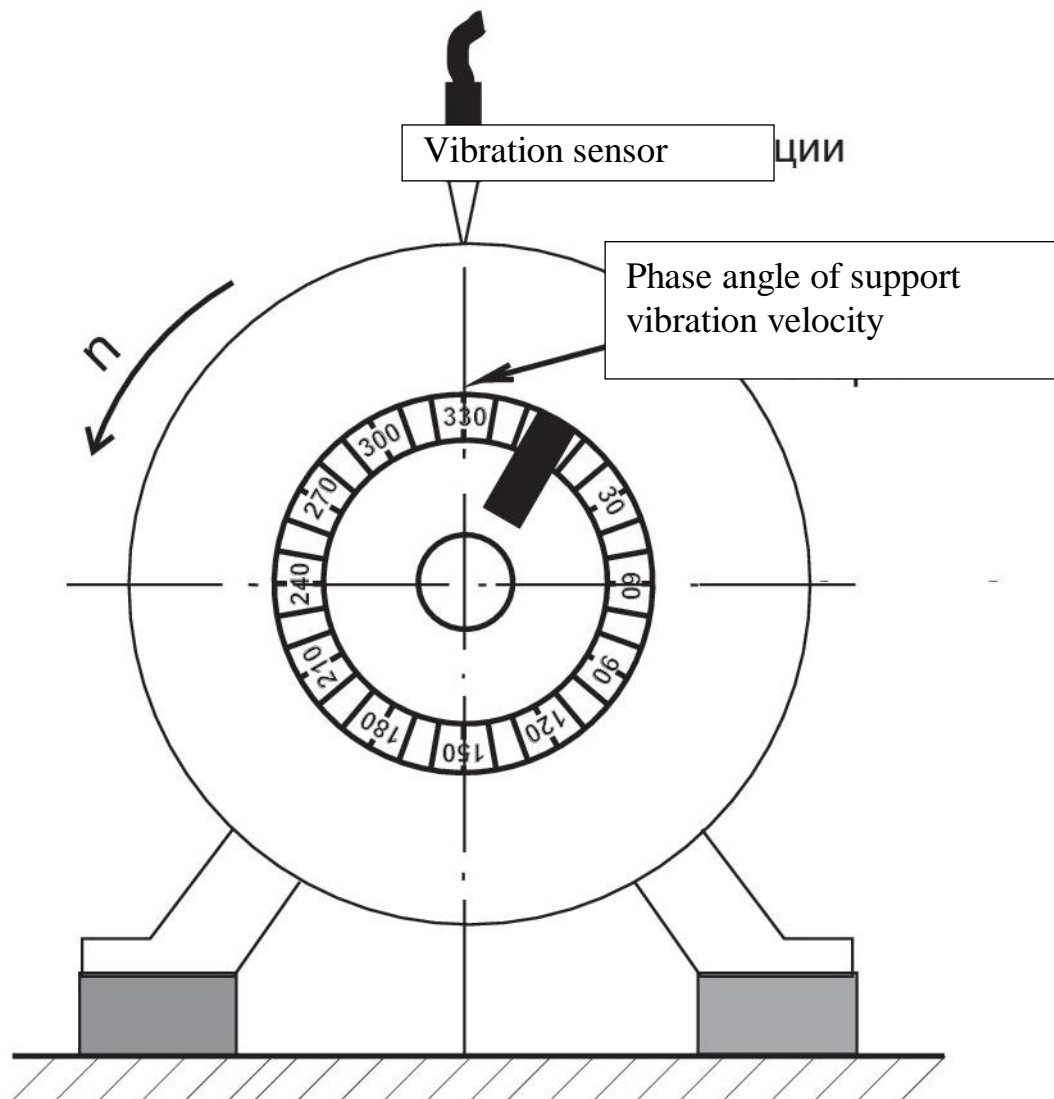



Fig. 7.3. Relative position of vibration sensor and phase angle of support vibration velocity

### Notes

1. In case of one-plane balancing, the phase angle of the support vibration velocity corresponds to the «high spot».

2. If there is no vibration at the rotor rotation speed (vibration velocity is less than 0.4 mm/s), the display will show the message «**No imbalance**».

By further pressing button “Enter”, the display will show icon «», and after 3 s - the menu.

3. In case of balancing the rotor, the indicator allows selection of menu items only from bottom to top!

4. In case of balancing the rotor, a long (more than 2 s) pressing of button "Enter" returns the indicator to the menu. In this case, the icon «▶» will be set opposite the menu item that was previously active.

7.3.4. By pressing buttons «▲», «▼», set on the display the value of the phase angle of the vibration velocity of support 1, and press «Enter».

7.3.5 After the message «**Stop the machine**» appears, stop the machine and press «Enter».

7.3.6 Set the value of the rotor mass on the display and press «Enter».

### **Note**

As the values of such parameters as the rotor mass, the test mass installation radius, the actual test mass and the correction mass installation radius are entered into the indicator memory, the indicator is allowed to return to the state of entering the value of the previous parameter. To do this, press the button «Enter», holding it down, press button «▲», and then release both buttons.

7.3.7 Set on the display the value of the radius of installation of the test mass  $M_{t1}$  and press «Enter». In this case, the display will show the calculated value of the test mass  $M_{t1c}$ .

7.3.8 Set on the display the value of the actual test mass  $M_{t1}$ , chosen according to the recommended calculated value  $M_{t1c}$ , and press «Enter».

### **Note**

In case of absence of data on the rotor mass, the test mass  $M_{t1}$  is chosen empirically so that the value of the vibration velocity of support 1 or its phase angle changes by about 20-40%.

7.3.9 Install the test mass  $M_{t1}$  on the correction plane on the side of support 1 under an angle  $\angle M_{t1}$ , which differs from the phase angle of the vibration velocity of support 1 by approximately  $\pm 90$  degrees.

7.3.10 Set on the display the value of the installation angle of the test mass  $M_{t1}$  and press «Enter».

7.3.11 Start the machine (the first startup), set the sensor to support 1 and press «Enter».

7.3.12 Implement recommendations of Items 7.3.2 – 7.3.4.

7.3.13 After message «**Stop the machine**» appears, stop the machine, remove the test mass  $M_{t1}$  and press «**Enter**».

7.3.14 Set on the display the value of the radius of installation of the correction mass  $M_{c1}$  and press «**Enter**».

7.3.15 View on the display the value of  $M_{c1}$  and its phase angle  $\angle M_{c1}$ , and switch off the indicator.

7.3.16 Place the correction mass  $M_{c1}$  on the correction plane on the side of support 1.

7.3.17 Carry out the test start of the machine and switch on the indicator.

7.3.18 Select the item «**Check of imbalance**» and press «**Enter**».

7.3.19 Aiming the stroboscope at the scale dial, make sure that the rotor rotation speed has remained unchanged, and press «**Enter**».

7.3.20 After installing the sensor on the points marked on support 1, measure the vibration velocities.

If the satisfactory results are obtained, stop the machine and switch off the indicator. Otherwise, the balancing shall be repeated.

#### 7.4 Two-plane balancing of the rotor

7.4.1 Install the sensor on support 1 and press «**Enter**».

7.4.2 Measure the value of vibration velocity of support 1 and press «**Enter**».

7.4.3 Install the sensor on support 2 and press «**Enter**».

7.4.4 Measure the value of vibration velocity of support 2 and press «**Enter**».

7.4.5 Place the sensor on the support indicated on the display and press «**Enter**».

7.4.6 In 10-15 seconds after the appearance of the message «**Wait for stroboscope to switch on**», the message «**Look at angle**» will appear and the stroboscope will switch on.



Aim the stroboscope at the scale dial, determine the value of the phase angle of the vibration velocity of the support, on which the sensor is installed (it shall be borne in mind that the place on the dial marking corresponding to the determined angle is in the same axial plane with the sensor on the sensor side) and press «**Enter**» (Fig. 7.3).

## Notes

1. If there is no vibration at the rotor speed (vibration velocity is less than 0.4 mm/s), the display will show message «**No imbalance**» on both supports. By further pressing the «**Enter**» button, the display will show icon «», and, after 3 s, the menu.

2. For balancing the rotor, the indicator allows selection of menu items only from bottom to top!

3. During balancing the rotor, long (more than 2 s) pressing of button «**Enter**» returns the indicator to the menu. In this case, icon «» is set opposite the menu item that was previously active.

7.4.7 By pressing buttons «», «» set on the display the value of the phase angle of the vibration velocity of the support, on which the sensor is installed, and press «**Enter**».

7.4.8 Repeat the instructions of Items 7.4.5 - 7.4.7. It shall be borne in mind that you will no longer have to wait for the stroboscope to switch on.

7.4.9 After message «**Stop machine**» appears, stop the machine and press «**Enter**».

7.4.10 Set the rotor mass on the display and press «**Enter**».

7.4.11 Set on the display the value of the installation radius of test mass  $M_{t1}$  and press «**Enter**». In this case, the display will show the calculated value of the test mass  $M_{t1c}$ .

7.4.12 Set on the display the value of the actual test mass  $M_{t1}$  chosen according to the recommended calculated value  $M_{t1c}$ , and press «**Enter**».

## Note

In case of absence of the data on the rotor mass, the test mass  $M_{t1}$  is selected empirically so that the value of the vibration velocity of support 1 or its phase angle changes by about 20-40%.

7.4.13 Install test mass  $M_{t1}$  on the correction plane on the side of support 1 under an angle  $\angle M_{t1}$ , which differs from the phase angle of the vibration velocity of support 1 by approximately  $\pm 90$  degrees.

7.4.14 Set on the display the value of the installation angle of the test mass  $M_{t1}$  and press «**Enter**».



7.4.15 Start the machine (first startup), install the sensor on support 1 and press «**Enter**».

7.4.16 Implement the instructions of Items 7.4.2 – 7.4.8.

7.4.17 After message «**Stop machine**» appears, stop the machine, remove the test mass  $M_{t1}$  and press «**Enter**».

7.4.18 Set on the display the value of the radius of installation of the test mass  $M_{t2}$  and press «**Enter**». In this case, the display will show the calculated value of the test mass  $M_{t2c}$ .

7.4.19 Set on the display the value of the actual test mass  $M_{t2}$  chosen according to the recommended calculated value  $M_{t2c}$ , and press «**Enter**».

7.4.20 Place the test mass  $M_{t2}$  on the correction plane on the side of support 2 under an angle  $\angle M_{t2}$ , which differs from the phase angle of the vibration velocity of support 2 by approximately  $\pm 90$  degrees.

7.4.21 Set on the display the value of the installation angle of the test mass  $M_{t2}$  and press «**Enter**».

7.4.22 Start the machine (the second startup), install the sensor to support 1 and press «**Enter**».

7.4.23 Implement the instructions of Items 7.4.2 - 7.4.8.

7.4.24 After message «**Stop machine**» appears, stop the machine, remove test mass  $M_{t2}$  and press «**Enter**».

7.4.25 Set the value of the radius of installation of correction mass  $M_{c1}$  on the display and press «**Enter**».

7.4.26 Set on the display the value of the radius of installation of correction mass  $M_{c2}$  and press «**Enter**».

7.4.27 See at the display the values of  $M_{c1}$ ,  $M_{c2}$  and their phase angles  $\angle M_{c1}$ ,  $\angle M_{c2}$ , and switch off the indicator.

7.4.28 Install correction mass  $M_{c1}$  on the correction plane on the side of support 1, and correction mass  $M_{c2}$  on the correction plane on the side of support 2.

7.4.29 Carry out the test startup of the machine and switch on the indicator.

7.4.30 Select item «**Check of imbalance**» and press «**Enter**».

7.4.31 Having aimed the stroboscope at the scale dial, make sure that the rotor rotation speed has remained unchanged, and press «**Enter**».

7.4.32 Having installed the sensor on the points marked on the supports, measure the vibration velocities.

When satisfactory results are obtained, stop the machine and switch off the indicator. Otherwise, the balancing shall be repeated.

## 7.5 Alignment of shafts of horizontal machines

7.5.1 Check the clutch for availability of play and, if any, eliminate it.

7.5.2 Fix the struts in prisms, install the prisms on the half-couplings (shafts) at a distance of at least 30 mm and not more than 250 mm from each other and fix them to the half-couplings, using chains and tension nuts (Figs. 7.4, 7.5).

In this case, the struts on the prisms shall be parallel to each other.

7.5.3 Choose a lock bar depending on the distance between the prisms (for a distance of less than 120 mm, a bar with a length of 150 mm is chosen), temporarily fasten it in the appropriate holder and fix the holder on the struts of the prism installed on the half-coupling of the not running (driven) machine at such height that in case of turning by  $\pm 90^\circ$  relative to the vertical, the lock bar does not catch the protruding surfaces.

7.5.4 Insert the dial indicators into the holes of the fastening bar (on one side) so that the connecting sleeves of each of them evenly protrude beyond the dimensions of the latter, fix them in a position convenient for reading the indications and install the fastening bar on the corresponding holder according to the selected version of the dial indicator location (Fig. 7.6).

7.5.5 Loosen the lock bar, and then fix it in such a position that when installing the holder with dial indicator on the prism struts, the measuring rods of the struts rest against the lock bar, and, when rotated by  $\pm 90^\circ$  relative to the vertical, it does not catch the protruding surfaces.

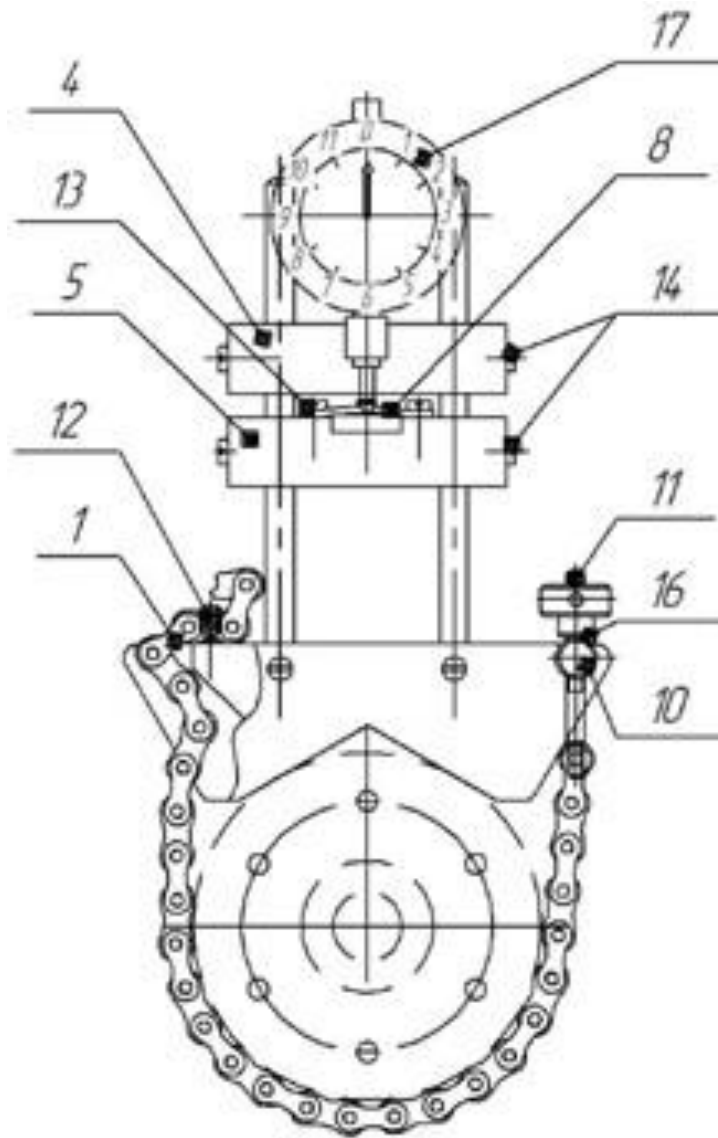

Fig. 7.4. Installation drawing of device for checking coaxial alignment of shafts with dials indicators:

- |   |                    |   |                            |
|---|--------------------|---|----------------------------|
| 1 | - chain,           | 4 | - holder of fastening bar, |
| 2 | - fastening prism, | 5 | - holder of lock bar       |
| 3 | - fastening bar,   | 6 | - strut,                   |



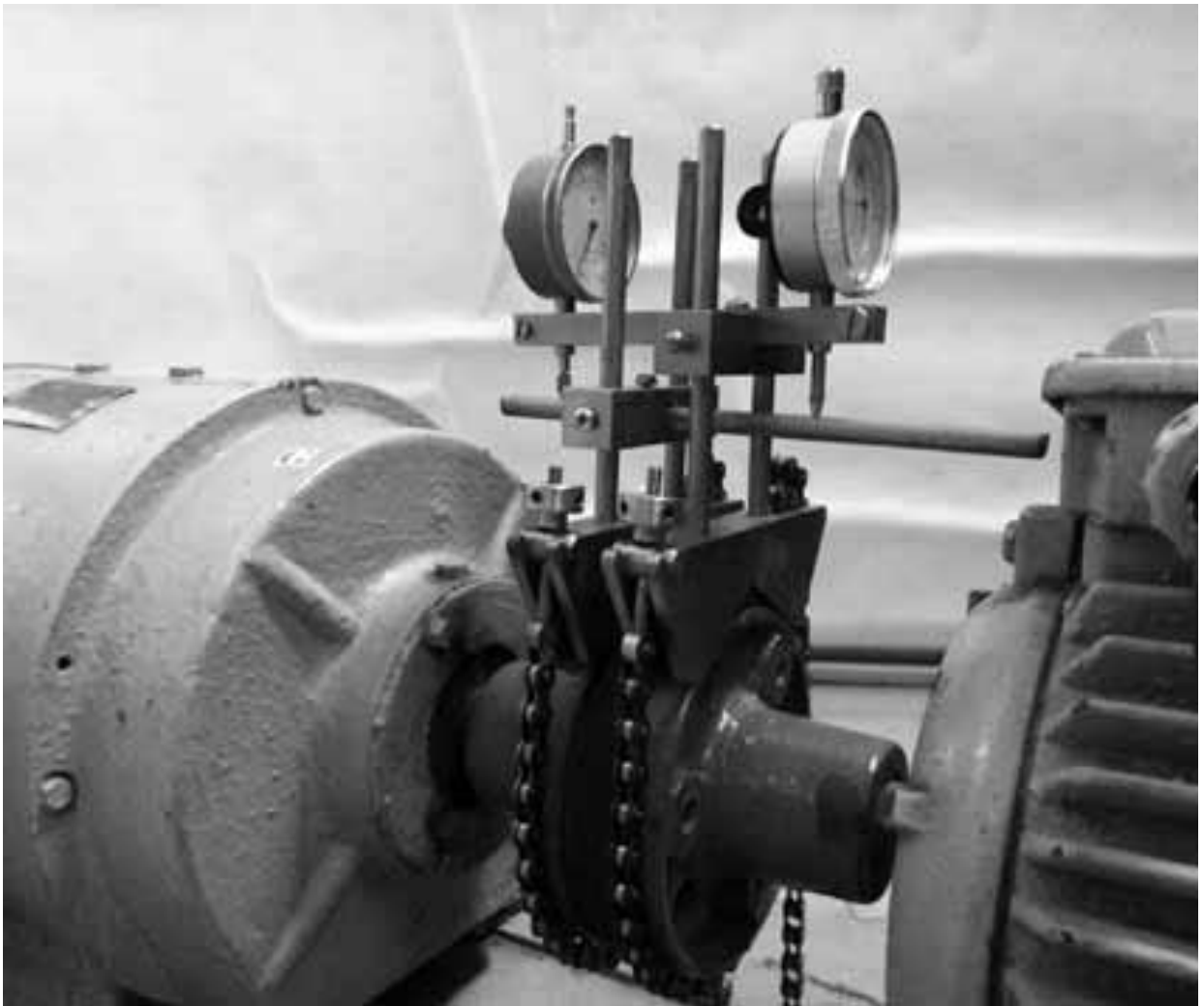

Fig. 7.5 General view of plant with installed device for check of coaxial alignment of shafts with dial indicators

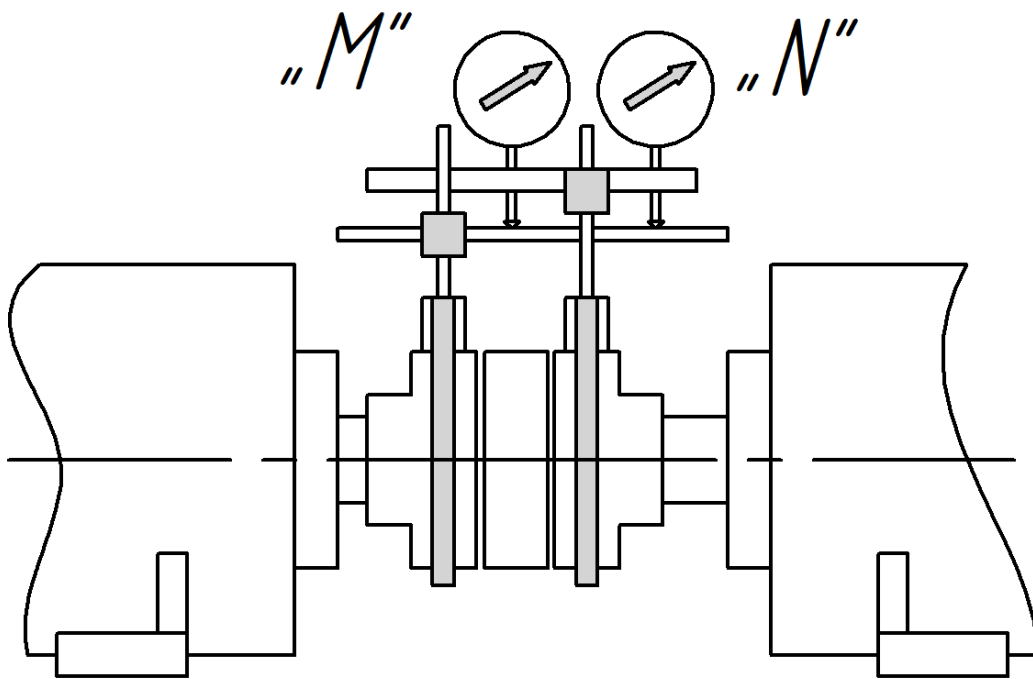
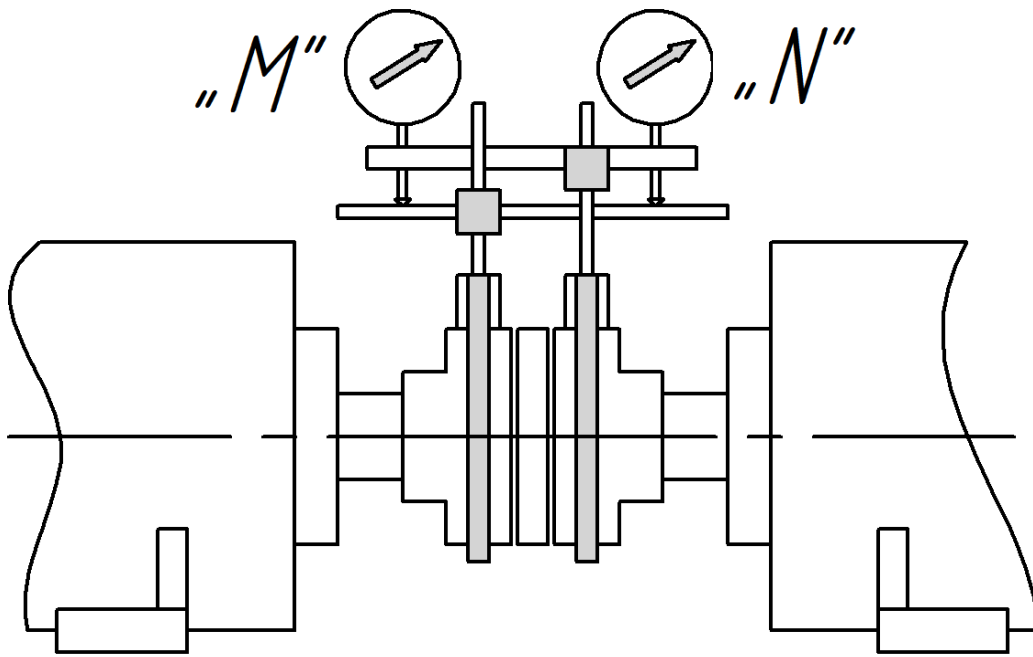



Fig. 7.6 Variants of location of dial indicators

7.5.6 Fix the holder with dial indicators on struts of the prism installed on the half-coupling of the moving (driving) machine at such a height that the reading from the dial indicator located on the side of the moving machine in the «0 h» position is in the middle of the small scale, and set the zero mark of its large scale opposite the arrow.

7.5.7 Loosen the connecting sleeve of the dial indicator located on the side of the not moving machine, set and fix the latter at such a height, so that its reading at «0 h» position is in the middle of the small scale, and set the zero mark of its large scale opposite the arrow.

7.5.8 Slowly turning the coupling from the «0 h» position to the «9 h» position, and then to the «3 h» position, make sure that the dial indicator readings do not go beyond the measurement range. When the specified limit values are reached, stop the turning and perform the required visual alignment, so that the requirements of this Item are met.

Table 7.2 Tolerances for shaft axial misalignment (according to the recommendations of LUDECA, CO., USA)

RPM	Angular (mm/100 mm) 		Parallel (mm) 	
	Excellent	Acceptable	Excellent	Acceptable
500	0.11	0.16	0.15	0.25
750	0.08	0.12	0.10	0.19
1000	0.06	0.09	0.07	0.13
1500	0.04	0.07	0.06	0.09
3000	0.02	0.04	0.03	0.05
6000	0.01	0.02	0.02	0.03

7.5.9 Check the availability of play of the support of the moving machine («soft foot») and, if any, eliminate it.

To check the availability of a «soft foot», it is recommended to do the following:

- 1) set the coupling to the «0 h» position;
- 2) number the bolts for fastening the supports;
- 3) check the tightening all four bolts and tighten them, if necessary;

4) Alternately loosening and tightening the bolts, record the readings of one of the dial indicators after loosening and tightening;

5) Compare the measurement results with the shaft axial for this plant. If they exceed 40% of the parallel misalignment tolerance, a «soft foot» is present.

7.5.10 Switch on the indicator, select item «**Alignment**» and press button «**Enter**».

7.5.11 Select item «Dimensions» and press «**Enter**».

7.5.12 Alternately set on the display the dimensions indicated by icon «▶» (between the dial indicator on the side of the moving machine and the dial indicator on the side of the not running machine, indicated on the display by «П» and «H» letters, respectively, between the dial indicator from the side of the moving machine and the jointing plane of the coupling, between the dial indicator from the side of the moving machine and the nearby supports of the moving machine, between the supports of the moving machine), measured with a measure tape, while pressing button «**Enter**» after each dimension setting.

7.5.13 Choose item «**Readings of dial indicators**» and press «**Enter**».

7.5.14 Set the coupling to the «9 h» position.

7.5.15 alternately read and set on the display the readings of the dial indicator on the side of the moving machine and the dial indicator on the side of the not moving machine being indicated by icon «▶», while pressing button «**Enter**» after each setting.

### **Note**

On switching off the indicator, all previously set values are saved in its memory.

7.5.16 Set the coupling to the «0 h» position, and follow the recommendations of Item 7.5.15.

7.5.17 Set the coupling to the, «3 h» position and follow the recommendations of paragraph 7.5.15.

7.5.18 Repeat the recommendations of Items 7.5.13 - 7.5.17 and compare the obtained readings of the dial indicators with the previous ones.

If the obtained readings of the dial indicators differ from the previous ones by more than 0.02 mm, then it is necessary to eliminate the appropriate



cause and again follow the recommendations of Items 7.5.13 - 7.5.17.

7.5.19 Select item «**Vertical alignment**» and press «**Enter**». At the same time, the display will show the designations of parallel (↔) and angular (↗) misalignments and their values in the vertical plane, the recommended values of the vertical displacements of the moving machine supports, the directions of displacements (indicated by flashing arrows) and the exact readings of the dial indicators, which shall be achieved after installing the calibrated plates under the supports of the moving machine.

### **Note**

If the values of parallel and angular misalignments are normal, then proceed to implementation of the recommendations of Item 7.5.22.

7.5.20 Loosen the bolts fastening the supports of the moving machine, underlay or remove the calibrated plates of the appropriate dimensions, tighten the bolts and press the button «**Enter**».

### **Note**

Always carry out loosening and tightening the bolts in the same order.

7.5.21 Repeat the recommendations of Items 7.5.13 - 7.5.17 (for recalculation of parallel and angular misalignments in the horizontal plane, which could change due to possible horizontal displacements of the moving machine during vertical alignment).

7.5.22 Choose item «**Horizontal alignment**» and press «**Enter**». At the same time, the display will show the values of the parallel and angular misalignments in the horizontal plane, the recommended values for displacements of the supports of the moving machine in horizontal direction, the directions of displacements and the exact readings of the dial indicators, which shall be achieved after the displacement of the supports.

### **Note**

If the values of parallel and angular misalignments are normal, then proceed to implementation of the recommendations of Item 7.5.25.

7.5.23 Loosen two bolts of the front support (on the drive side) and one of the bolts of the rear support (on the side opposite to the drive one) of the moving machine and make the recommended horizontal displacement of the front support.

Then tighten one of the bolts of the front support and loosen the previously tightened bolt of the rear support of the moving machine, make the recommended horizontal displacement of the rear support, tighten the bolts and press «**Enter**».

7.5.24 Repeat the recommendations of Items 7.5.13 - 7.5.17 (for calculation of the values of parallel and angular misalignments obtained after alignment).

7.5.25 Sequentially selecting the items «**Vertical alignment**», «**Horizontal alignment**» and pressing «**Enter**» after each selection, compare the values of parallel and angular misalignments obtained after alignment in the vertical and horizontal planes with the appropriate tolerances. If the latter are exceeded, repeat the alignment.

7.5.26 Switch off the indicator.

## **8 Control of indicator serviceability**

8.1 Connect the vibration sensor to the indicator and place it on a non-vibrating surface.

8.2 Switch on the indicator, select the item «**Check of vibration**» and press «**Enter**».

8.3 Press and hold the button «**▼**» until message «**Check of sensor**» appears on the display. Then press «**Enter**» and wait for message «**Sensor is OK**» to appear.

8.4 Switch off the indicator.

8.5 The indicator is serviceable if the requirement of Item 8.3 is met.

## **9 Operating and storage conditions**

9.1 Temperature range operation: -10°C to + 40°C (+14°F to +112°F).

9.2 Temperature range storage: -20°C to + 50°C (-4°F to +122°F).

9.3 Humidity: 0-80% relative humidity, non-condensing.

## 10 Acceptance certificate

Indicator IBR-02 No. \_\_\_\_\_ is in compliance with TC U 33.2-14105464.007:2008 and is found fit for regular service.

Chief of Quality Control Department

Seal here \_\_\_\_\_  
personal signature

\_\_\_\_\_  
name

\_\_\_\_\_  
date

## 11 Guarantee

11.1 The manufacturer guarantees the serviceability of the indicator if the owner observes the operation rules set forth in this operating manual.

11.2 The guaranteed period is 24 months from the date of sale.

11.3 During the guarantee period, the manufacturer undertakes to repair or replace the indicator free of charge. If the indicator fails, contact the manufacturer.

Sale date \_\_\_\_\_

### **Developer and manufacturer:**

TETRA CO., LTD.

18 Gudanova str., Kharkiv, Ukraine, 61024,

tel. / fax +380(57) 714-09-43,

tel. +380(57) 720-22-13, 714-38-38

[mark@tetra.kharkiv.com](mailto:mark@tetra.kharkiv.com),

[www.tetra.kharkiv.com](http://www.tetra.kharkiv.com)